

## Your contacts

### GERMANY

#### Baden-Württemberg

Alexander Bauer  
M +49 (0) 160 719 76 69  
alexander.bauer@duktus.com

#### Rhineland

Harald Oster  
M +49 (0) 172 73 12 936  
harald.oster@duktus.com

#### Saxony-Anhalt/Leipzig

Uwe Hoffmann  
M +49 (0) 172 72 21 174  
uwe.hoffmann@duktus.com

### AUSTRIA

#### Tyrol & Vorarlberg

Werner Siegele  
M +43 (0) 664 44 30 721  
werner.siegele@duktus.com

#### Vienna, Lower Austria, Burgenland

Robert Bladsky  
M +43 (0) 664 61 18 595  
robert.bladsky@duktus.com

### ITALY

#### South Tyrol/Trentino

Christoph Obkircher  
M +39 (0) 345 66 08 948  
christoph.obkircher@duktus.com

### WESTERN & NORTHERN EUROPE & POLAND

Duktus Rohrsysteme Wetzlar GmbH  
T +49 (0) 6441 49 2260  
F +49 (0) 6441 49 1613  
manfred.hoffmann@duktus.com

#### Bavaria

Wilhelm Faulstich  
M +49 (0) 172 73 14 807  
wilhelm.faulstich@duktus.com

#### Rhine-Main

Heinz-Jörg Weimer  
M +49 (0) 151 16 76 87 62  
heinz-joerg.weimer@duktus.com

#### Thuringia

Uwe Strich  
M +49 (0) 172 81 23 089  
uwe.strich@duktus.com

#### Upper Austria, Northern Salzburg

Ingo Krieg  
M +43 (0) 664 61 18 599  
ingo.krieg@duktus.com

#### Vienna, Lower Austria, Burgenland

Gerald Pasa  
M +43 (0) 664 32 28 835  
gerald.pasa@duktus.com

### SOUTH-EASTERN EUROPE & CIS

Duktus Tiroler Rohrsysteme GmbH  
T +43 (0) 5223 503-105  
F +43 (0) 5223 503-111  
andreas.weiler@duktus.com

#### Berlin/Brandenburg/Mecklenburg-Vorpommern

Lutz Rau  
M +49 (0) 172 72 21 175  
lutz.rau@duktus.com

#### Saarland/Southern Palatinat

Werner Fick  
M +49 (0) 172 67 18 180  
werner.fick@duktus.com

#### Applications Engineering

T +49 (0) 6441 49 1251  
anwendungstechnik@duktus.com

#### Styria, Carinthia, Southern Salzburg

Walter Korenjak  
M +43 (0) 664 54 88 353  
walter.korenjak@duktus.com

#### Styria, Carinthia

Rudolf Stelzl  
M +43 (0) 664 83 48 083  
r.stelzl@aqua-austria.at

### CZECH REPUBLIC AND SLOVAK REPUBLIC

Duktus litinové systémy s.r.o.  
T +420 311 611 356  
F +420 311 624 243  
obchod@duktus.cz

#### Hesse/Southern Lower Saxony

Karl-Wilhelm Römer  
M +49 (0) 172 72 21 162  
karl-wilhelm.roemer@duktus.com

#### Saxony

Michael Klee  
M +49 (0) 172 72 39 895  
michael.klee@duktus.com

#### Styria, Carinthia

Rudolf Stelzl  
M +43 (0) 664 83 48 083  
r.stelzl@aqua-austria.at

### MIDDLE EAST AND NORTH AFRICA

Duktus Pipe Systems FZCO  
T +971 (0) 4 886 56 80  
F +971 (0) 4 886 56 40  
sales@duktus.ae

## Ductile iron pipe systems with BLS<sup>®</sup>/VRS<sup>®</sup>-T restrained joints



- Operating pressures up to 100 bars
- No thrust blocks needed
- Quick and easy to assemble
- Suitable for trenchless laying techniques
- Comprehensive range of fittings

#### Duktus S.A.

Innsbrucker Straße 51  
6060 Hall in Tirol  
Austria

T +43 (0) 5223 503-215

www.duktus.com

#### Duktus Rohrsysteme Wetzlar GmbH

Sophienstraße 52-54  
35576 Wetzlar  
Germany

T +49 (0) 6441 49 2401  
F +49 (0) 6441 49 1455

www.duktus.com

#### Duktus Tiroler Rohrsysteme GmbH

Innsbrucker Straße 51  
6060 Hall in Tirol  
Austria

T +43 (0) 5223 503-0  
F +43 (0) 5223 43619

www.duktus.com

#### Duktus litinové systémy s.r.o.

Košťálkova 1527  
266 01 Beroun  
Czech Republic

T +420 311 611 356  
F +420 311 624 243

www.duktus.cz

#### Duktus Pipe Systems FZCO

South Jebel Ali Free Zone  
JAFZA View 18/Office No. 909  
Dubai/U.A.E.

T +971 (0) 4886 56 80  
F +971 (0) 4886 56 40

www.duktus.ae

# Technical data

## The BLS®-/VRS®-T joint

is a socket joint which operates on the basis of positive interengagement and which is restrained against longitudinal forces. Forces generated by internal pressure or external loads are absorbed by the pipeline and transferred to the surrounding soil by skin friction. Forces are transmitted between the individual pipes by means of a weld bead on the spigot end of the pipe or fitting. Via a mechanical lock, the weld bead transmits the forces into the locking chamber in the next pipe.

Extremely high forces which would cause damage to the majority of other joints can be transmitted in this way. For example, depending on the nominal size, operating pressures of more than 100 bars or permitted tractive forces of up to 200 kN can be obtained.

Even though the BLS®-/VRS®-T joint is able to withstand extremely high loads, it is still flexible, easy and particularly quick to assemble.

The joint will accept an angular deflection of up to 5° and a pipe string can thus be laid or pulled in to a radius of only 69 m – without fittings and without thrust blocks. The very short assembly times of around 5 minutes for the DN 80 size to a maximum of 30 minutes for the DN 1000 size do everything else that is needed to make the BLS®-/VRS®-T joint the joint that can be used almost anywhere with cast iron pipes.

One of the greatest advantages of the BLS®-/VRS®-T joint is the clamping ring. Normally, to give a positively interengaged joint, a weld bead would have to be applied retrospectively to the cut end when pipes are cut. On pipes of nominal sizes from DN 80 to DN 500 this can be almost entirely avoided by using the clamping ring.

As a system, the BLS®-/VRS®-T joint is available with a comprehensive range of fittings and with gate valves, butterfly valves, hydrants and air-bleeders.

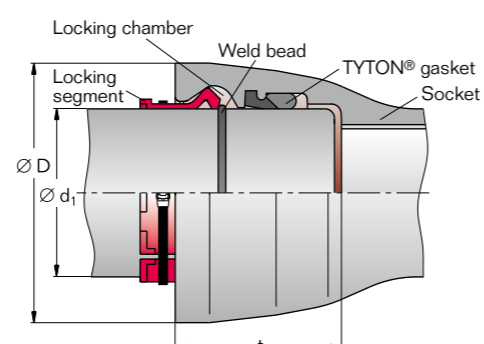
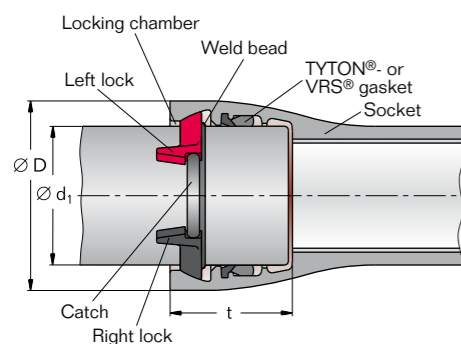
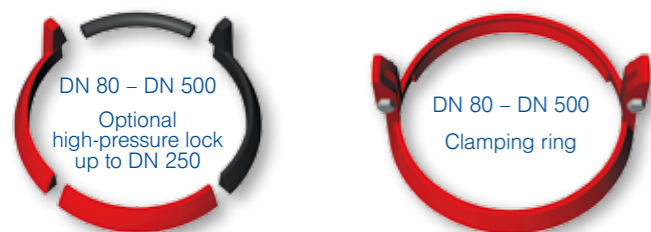

# Areas of application

- As a replacement for concrete thrust blocks
- For angular deflections of up to 5°
- For operating pressures up to 100 bars
- Wide range of fittings, inc. gate valves, butterfly valves, hydrants, etc.
- High-pressure applications
- Pipe systems for snow-making facilities
- Turbine pipelines
- Fire-extinguishing pipes
- Culvert pipelines
- Bridge pipelines
- Collector pipes
- Trenchless laying
- Horizontal direction drilling (HDD)
- Ploughing-in with a rocket plough
- Press-pull technique/auxiliary tube technique
- Burst lining
- Pipe relining

DN	d <sub>1</sub> [mm]	D [mm] <sup>1)</sup>	t [mm]	Component operating pressure PFA [bar] <sup>2)</sup>	Permitted tractive force F [kN] <sup>3)</sup>	Permitted angular deflection [°]	Number of locking segments
80 <sup>5)</sup>	98	156	127	100/110 <sup>4)</sup>	115	5	2/3 <sup>4)</sup>
100 <sup>5)</sup>	118	182	135	75/100 <sup>4)</sup>	150	5	2/3 <sup>4)</sup>
125 <sup>5)</sup>	144	206	143	63/100 <sup>4)</sup>	225	5	2/3 <sup>4)</sup>
150 <sup>5)</sup>	170	239	150	63/75 <sup>4)</sup>	200	5	2/3 <sup>4)</sup>
200	222	293	160	42/63 <sup>4)</sup>	350	4	2/3 <sup>4)</sup>
250	274	357	165	40/44 <sup>4)</sup>	375	4	2/3 <sup>4)</sup>
300	326	410	170	40	380	4	4
400	429	521	190	30	650	3	4
500	532	636	200	30	860	3	4
600	635	732	175	32	1525	2	9
700	738	849	197	25	1650	1.5	11
800	842	960	209	25	1460	1.5	14
900	945	1073	221	16/25 <sup>5)</sup>	1845	1.5	13
1000	1048	1188	233	10/25 <sup>5)</sup>	1560	1.5	16

1) Guideline value; 2) Operating pressure (PFA): allowable component operating pressure in bars. Basis for calculation was wall-thickness class K9, up to and including DN 250 with high-pressure lock; 3) When pipelines follow straight paths (max. deflection of 0.5° per pipe joint), the tractive forces can be raised by 50 kN. High-pressure locks are required for DN 80 - DN 250. 4) with high-pressure lock 5) Wall-thickness class K10



BLS®-/VRS® jointed valved tee with butterfly valve and gate valve



Pipe relining



Floating in a ductile cast iron pipeline



Temporary pipeline with BLS®-/VRS®-T joints